

## secuencia sistema constructivo

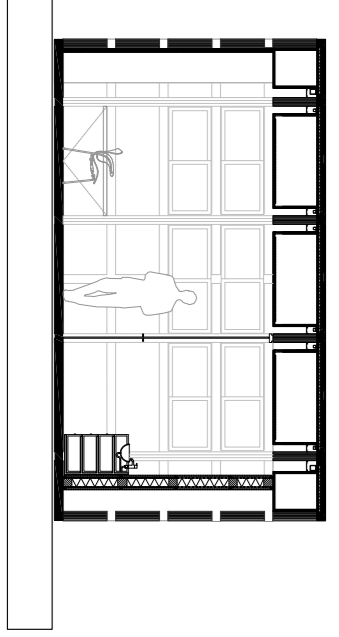

Implantación: e1/2500

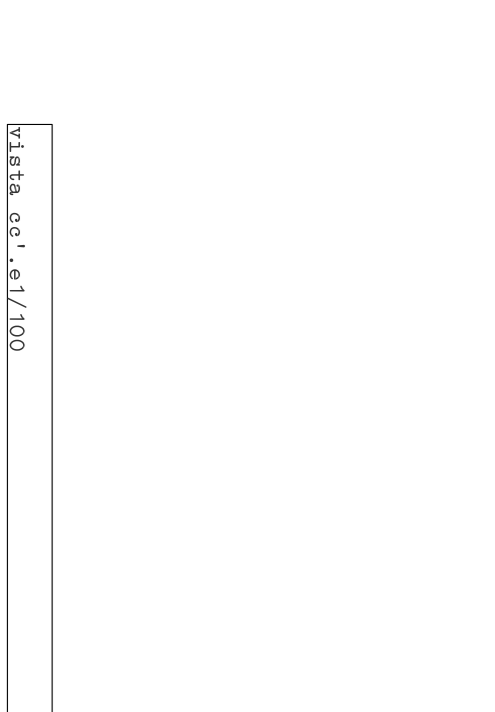
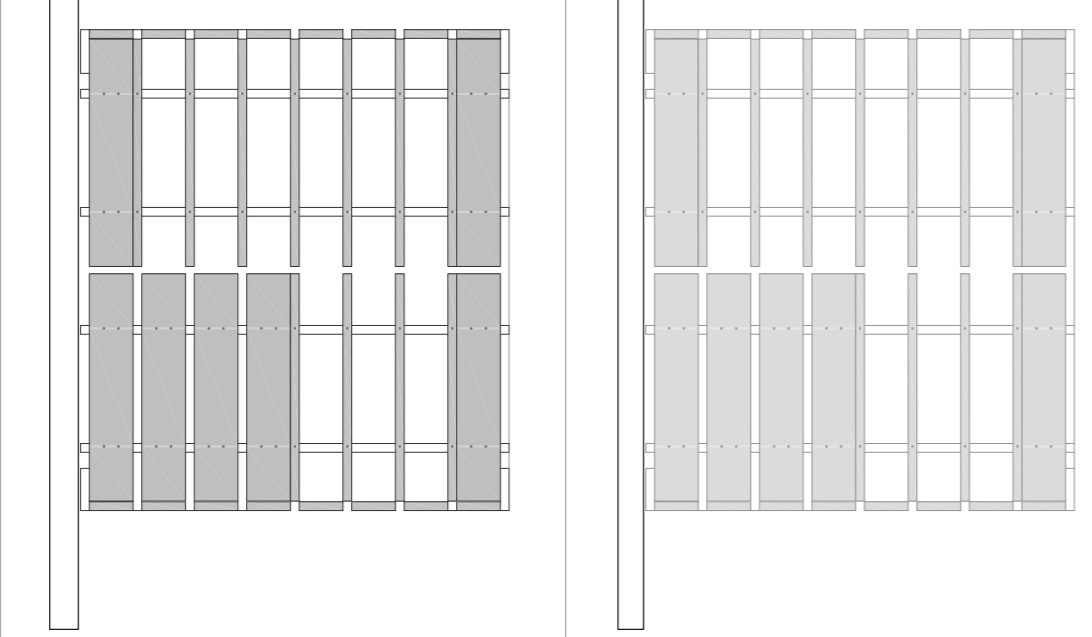
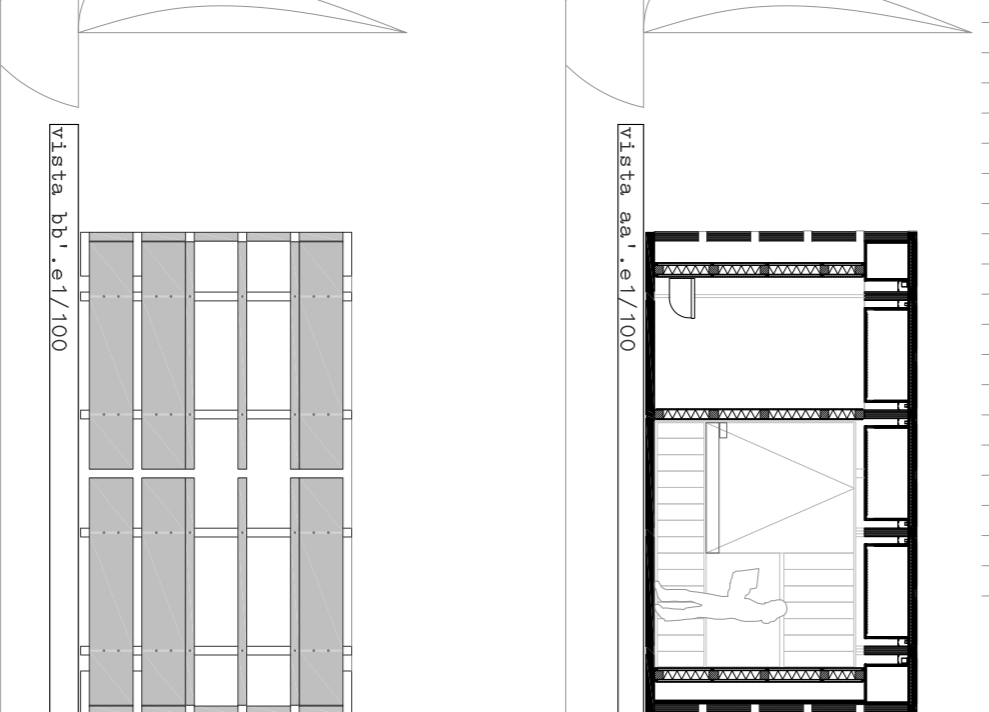
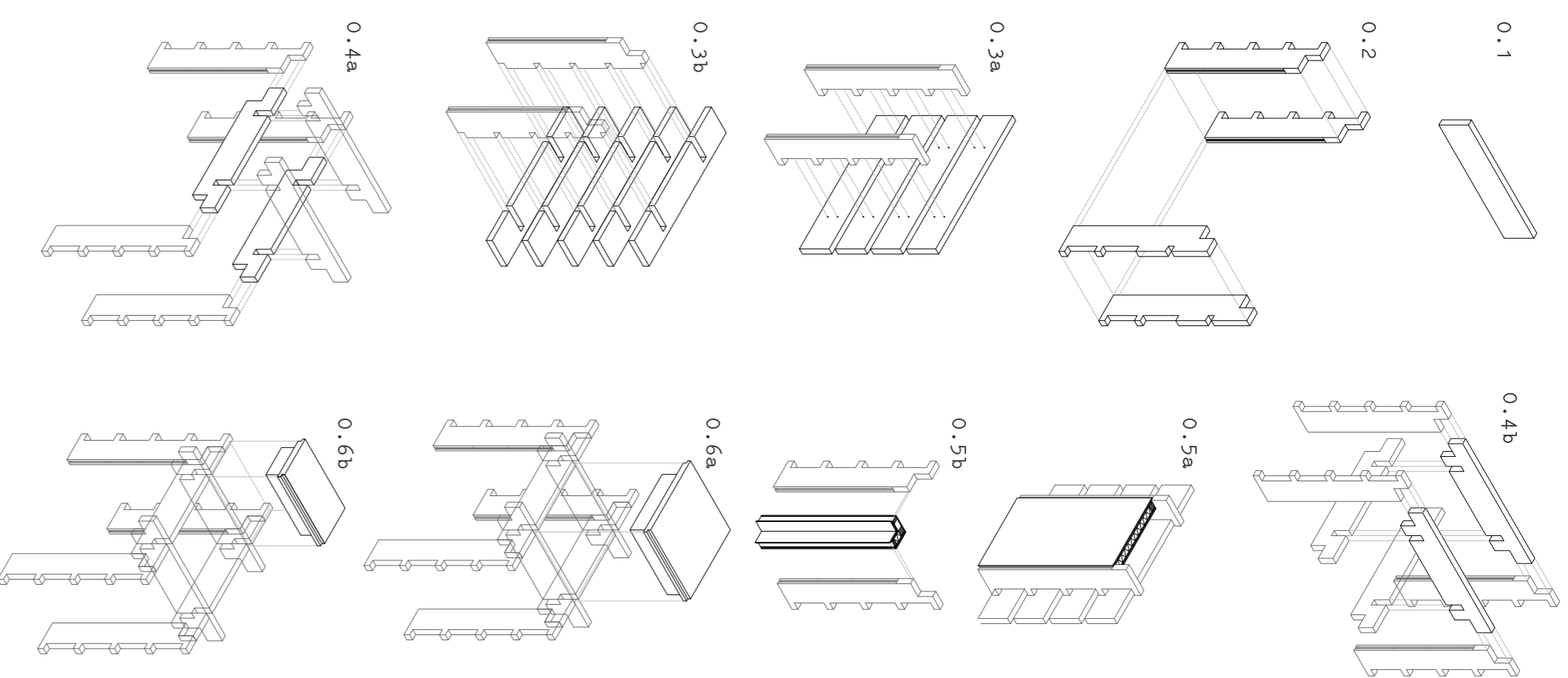
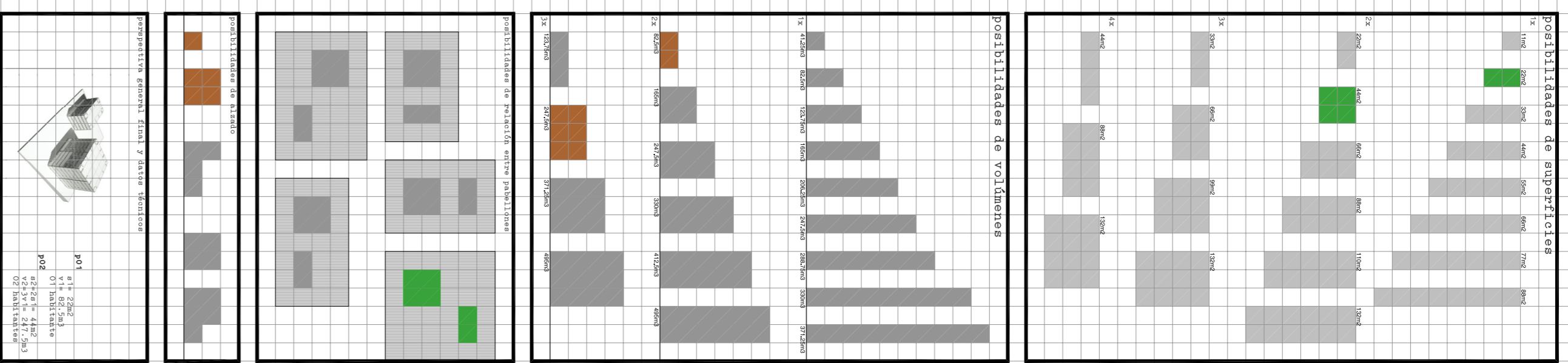
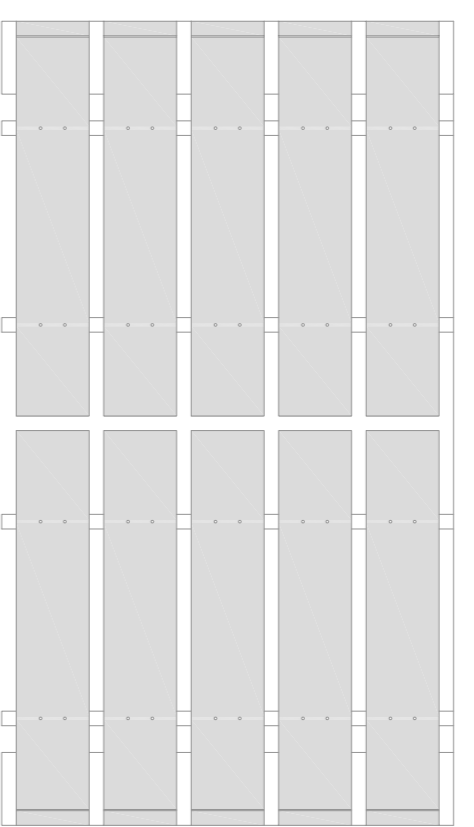
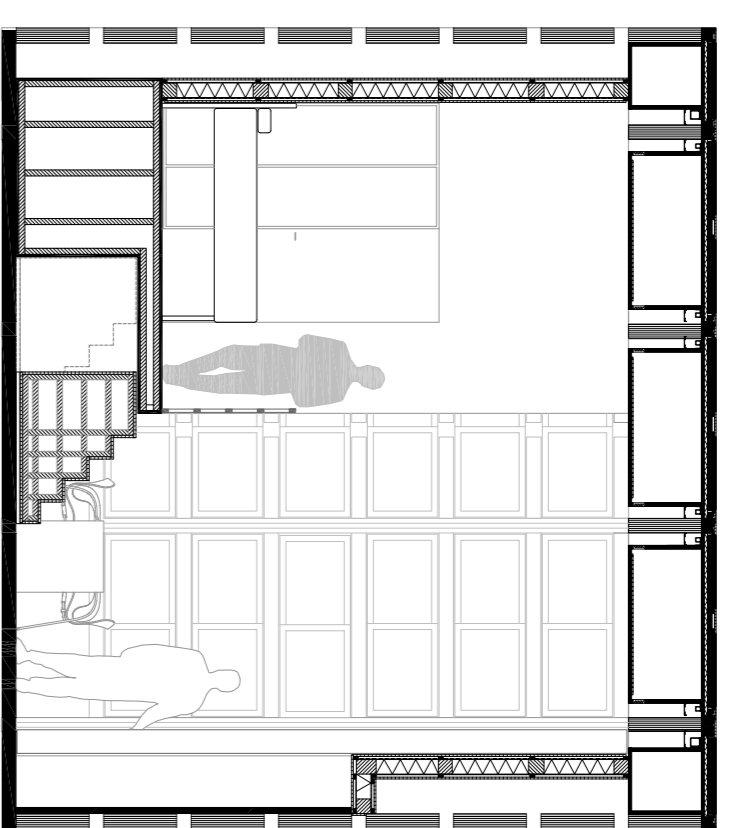
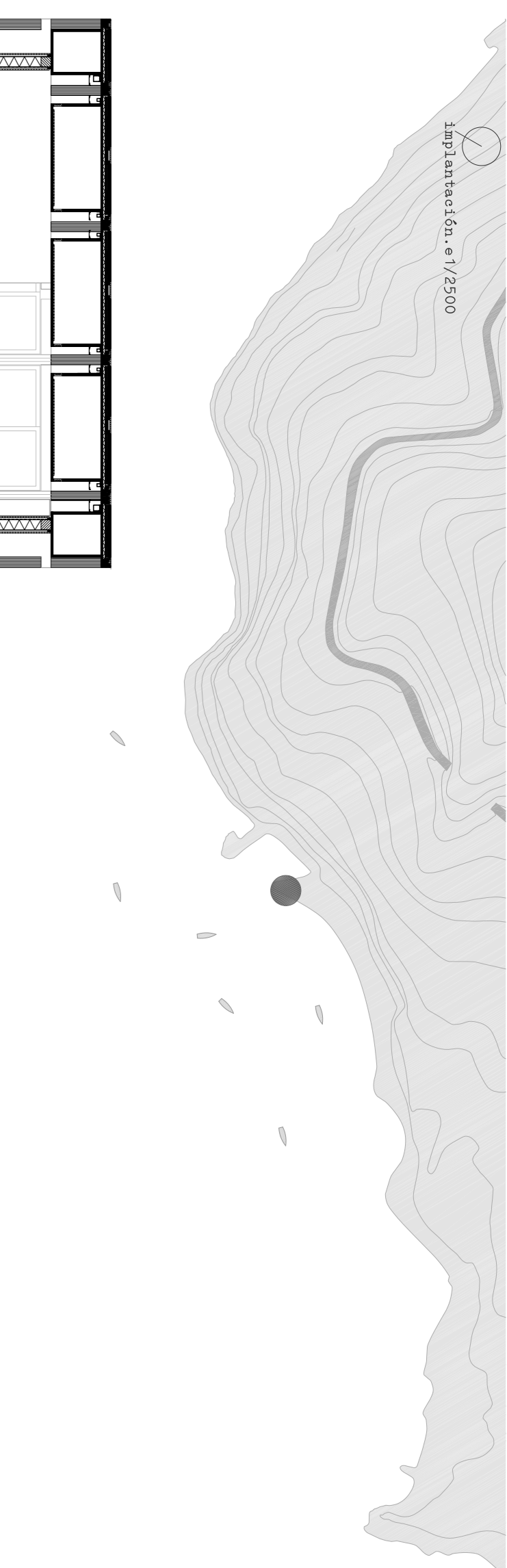

Vista s.d., a1/60

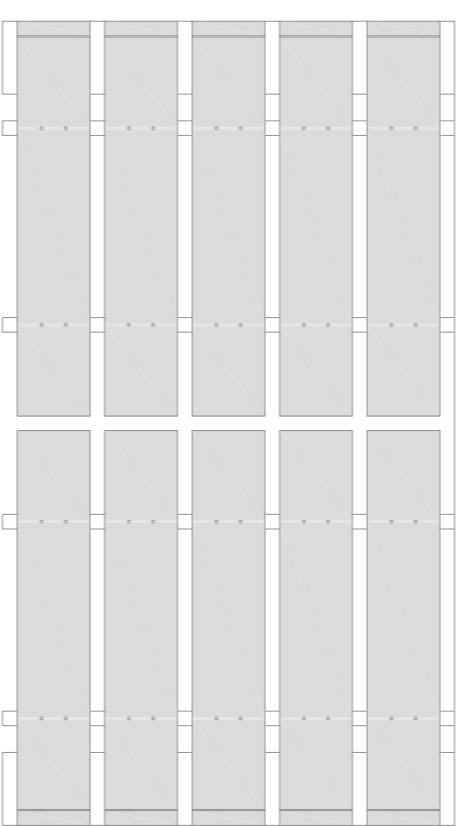
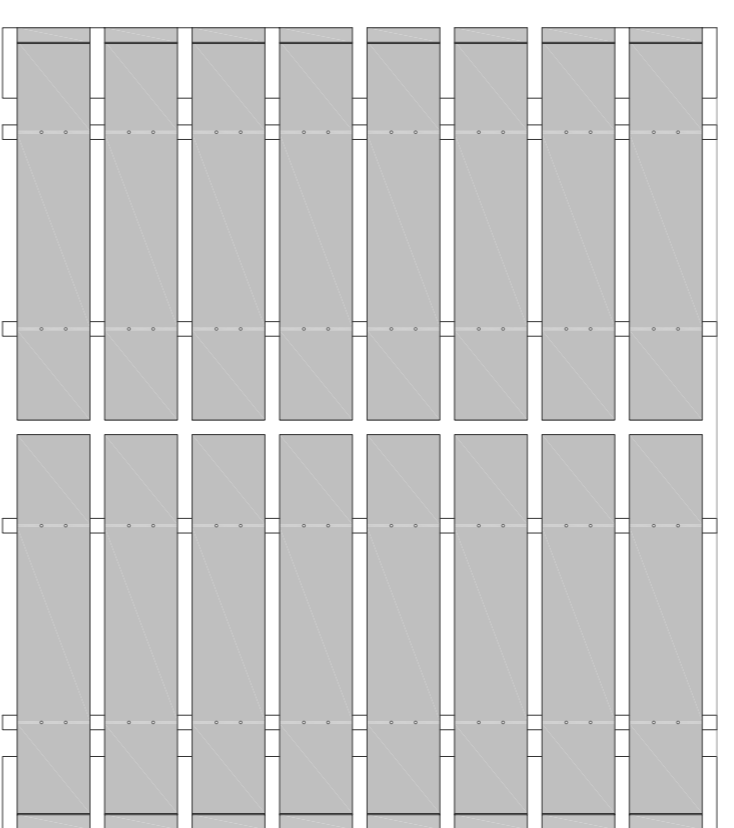

Vista s.d., a1/60

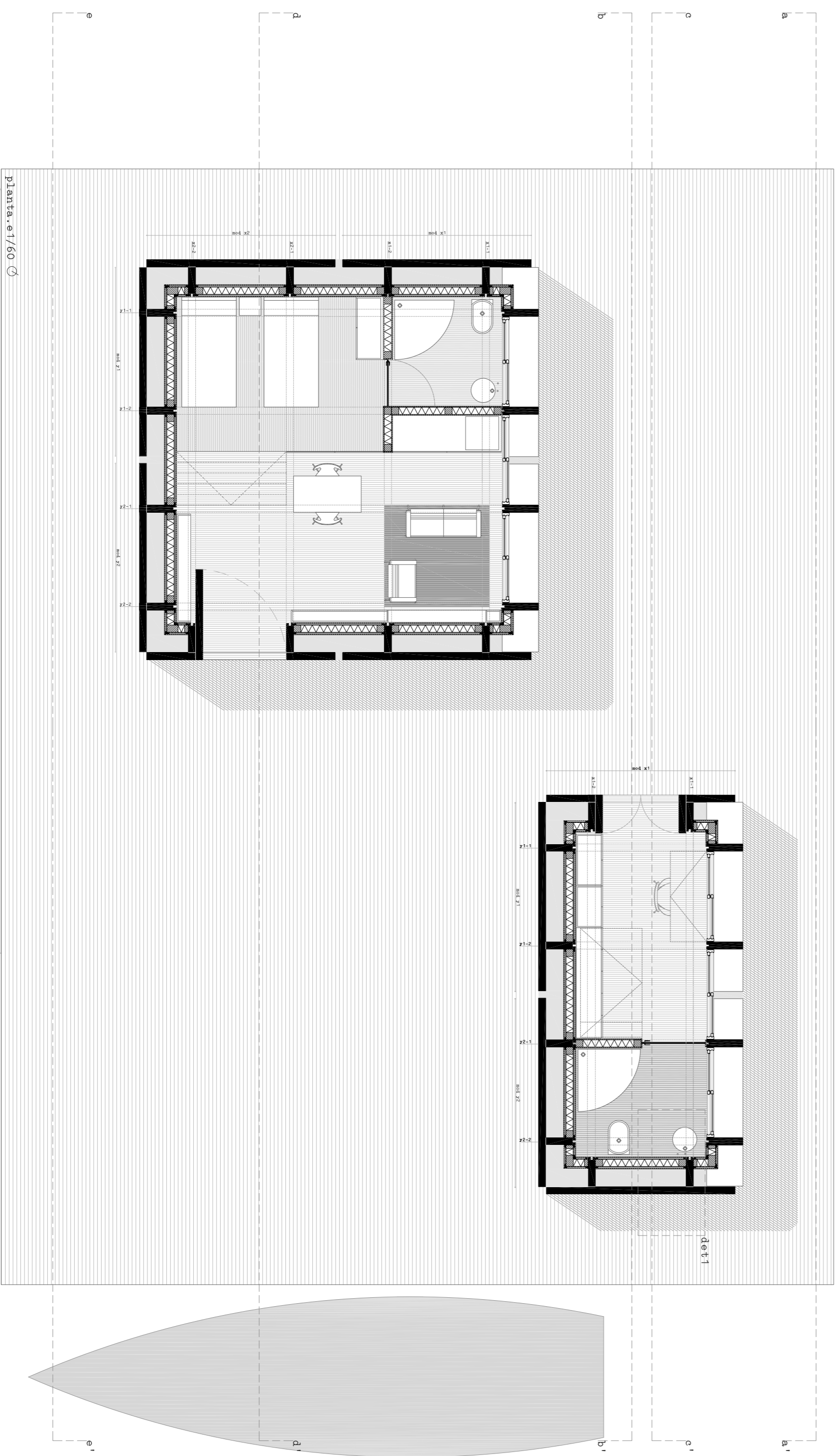

Planta: a1/60

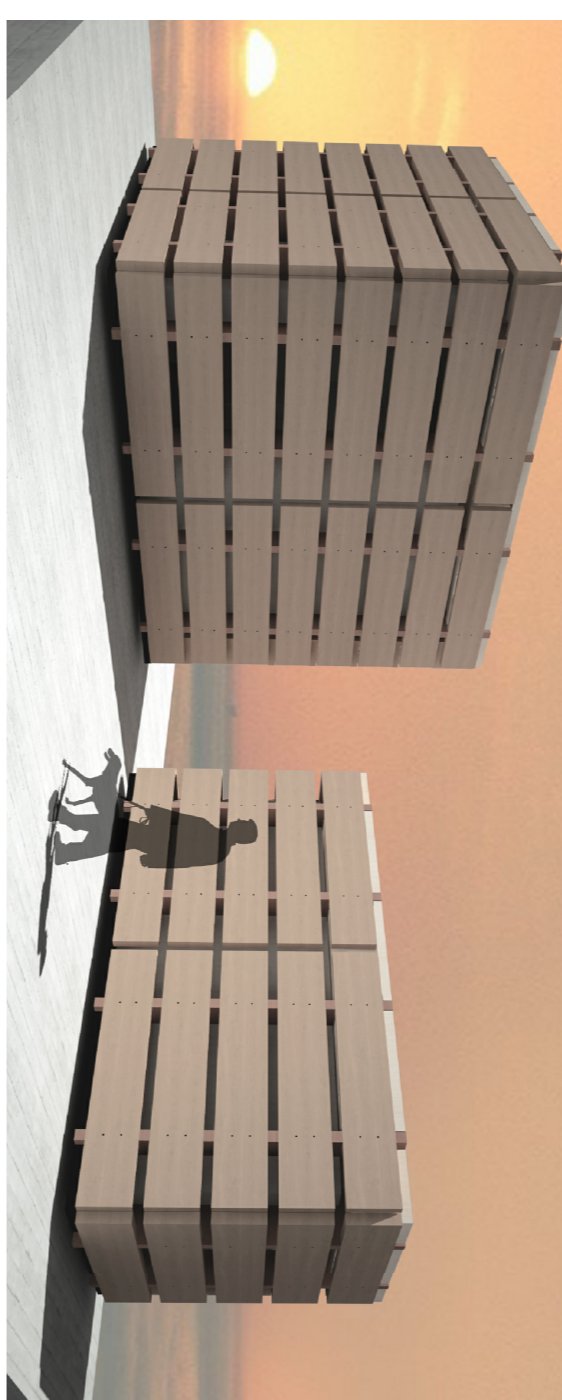
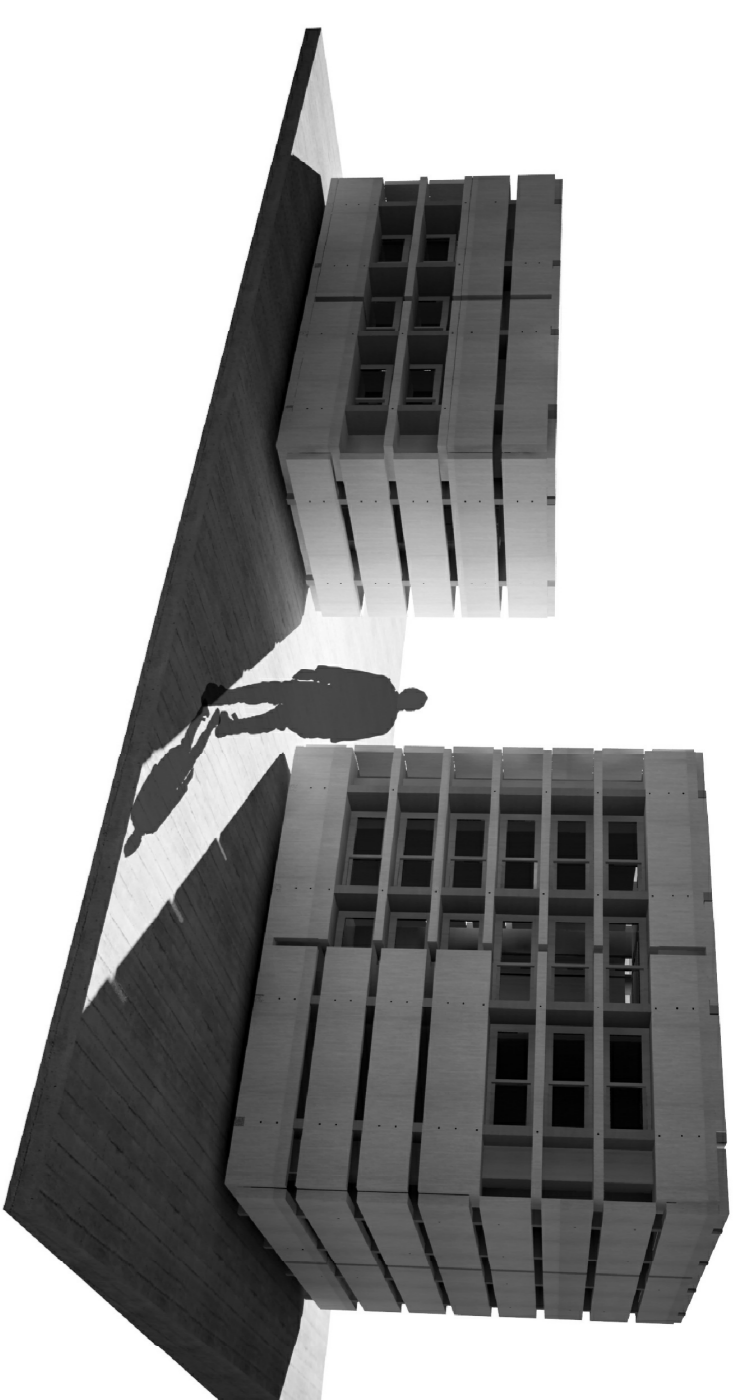

01. Fachada de madera. 02. Laminado de pino. 03. Laminado de pino. 04. Laminado de pino. 05. Laminado de pino. 06. Laminado de pino. 07. Laminado de pino. 08. Laminado de pino. 09. Laminado de pino. 10. Laminado de pino. 11. Laminado de pino. 12. Laminado de pino. 13. Laminado de pino. 14. Laminado de pino. 15. Laminado de pino. 16. Laminado de pino. 17. Laminado de pino. 18. Laminado de pino. 19. Laminado de pino. 20. Laminado de pino.

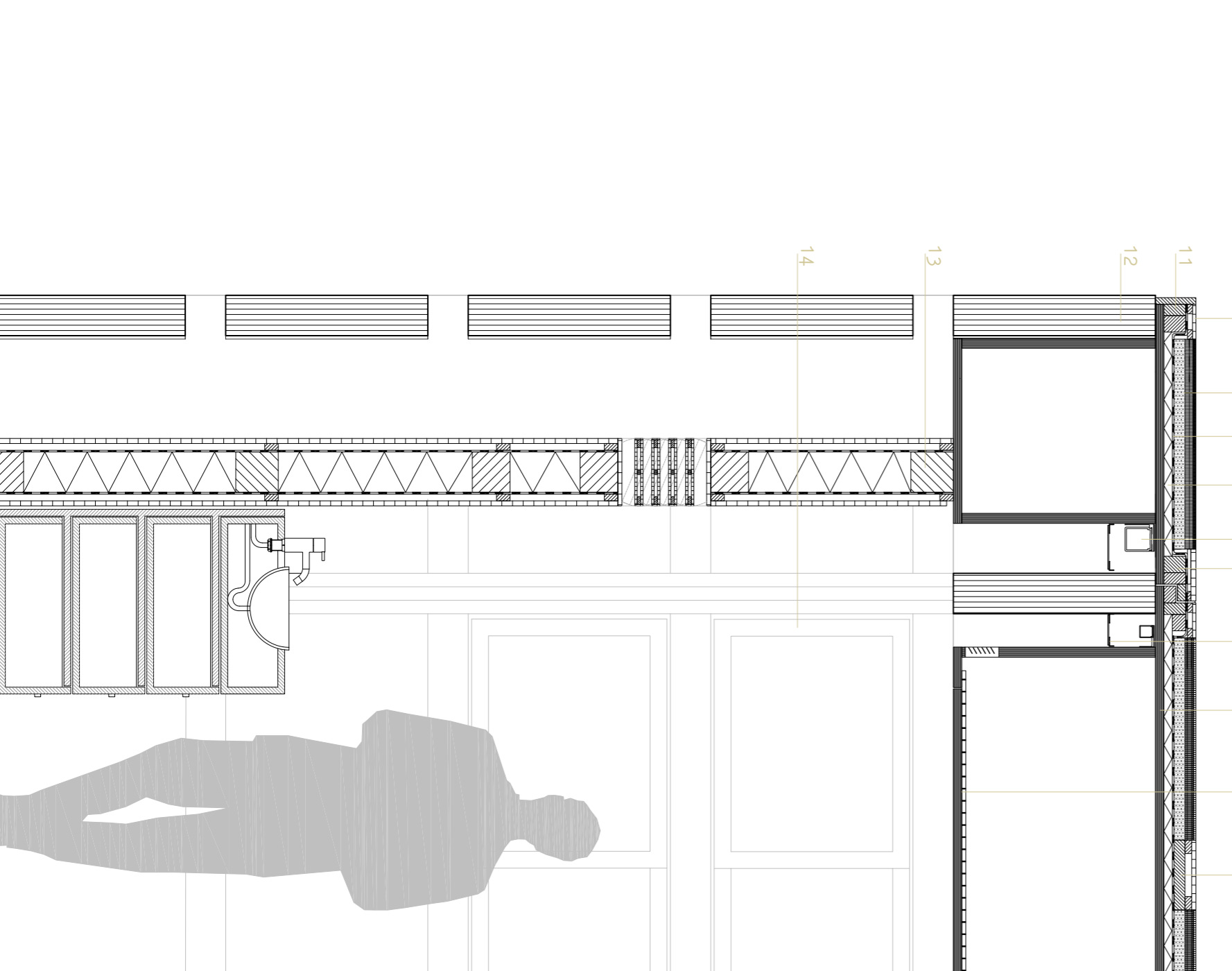

Detalle: a1/15